

## Technical Product Information No. 860 EN

### Hydraulically actuated clutch/brake combined unit series 0123 ♦ size 94- 98

| <b>Contents</b>                                | <b>Page</b> |
|--|-------------|
| About this Technical Product Information (TPI) | 2           |
| The ORTLINGHAUS numbering system               | 2           |
| About the product                              | 3           |
| Delivered state                                | 4           |
| Initial assembly and commissioning             | 5           |
| Maintenance                                    | 6           |
| Fault finding                                  | 7           |
| Complete assembly - only for customer service  | 8           |
| Spare parts                                    | 13          |
| Approved oils                                  | 16          |

## About this Technical Product Information (TPI)

### Who is this TPI directed at?

This TPI is directed at qualified personnel who

- are entrusted with the assembly, commissioning and operation of the product and who
- have obtained the necessary qualifications by reading and understanding the instructions by training or instruction

It is intended for

- Fitters at the manufacturer of the machine / plant
- Maintenance fitters at the machine users.

### What will you find in the TPI?

The TPI provides all the necessary information for the assembly and maintenance of the product described on the title page

### Notes on the symbols used in the text

On the pages which follow, important sections of text are highlighted with the following symbols.



This symbol means:

There is a risk of injury during the activity described or in operational running!



This symbol means:

There is a risk of material damage during the activity described or in operational running!



This symbol indicates sections of text to which particular attention must be paid.

### The Ortlinghaus numbering system

**Example:** 0 111 - 222 - 33 - 444 555

|                                 |       |  |       |  |       |  |       |  |       |
|---------------------------------|-------|--|-------|--|-------|--|-------|--|-------|
| 0 = Code for products           | _____ |  | _____ |  | _____ |  | _____ |  | _____ |
| Code number for the model range | _____ |  | _____ |  | _____ |  | _____ |  | _____ |
| Code number for design features | _____ |  | _____ |  | _____ |  | _____ |  | _____ |
| Size                            | _____ |  | _____ |  | _____ |  | _____ |  | _____ |
| Sequential number               | _____ |  | _____ |  | _____ |  | _____ |  | _____ |
| Other design features           | _____ |  | _____ |  | _____ |  | _____ |  | _____ |



Pass this TPI on to your customers ! You can either order further copies of this TPI from us or you are free to make copies, for use by your customers.

## About the product

### Purpose and mode of functioning of the clutch/brake combined unit

Hydraulically-actuated clutch/brake combined units for presses are characterised by the low amount of space they take up, by their low moment of inertia and by the high rates at which they can be reliably engaged and disengaged. They are maintenance-free to a large extent. In addition their multi-plate form of construction enables them to transmit high torques even when thermal loadings are high.

When fitted with a sealed housing cup, they can cause no contamination of the ambient air in the form of dust from the linings or oil mist. Furthermore, even without additional sound insulation, the clutch produces only a low level of noise (around 85 dB (A)) when being engaged/disengaged.

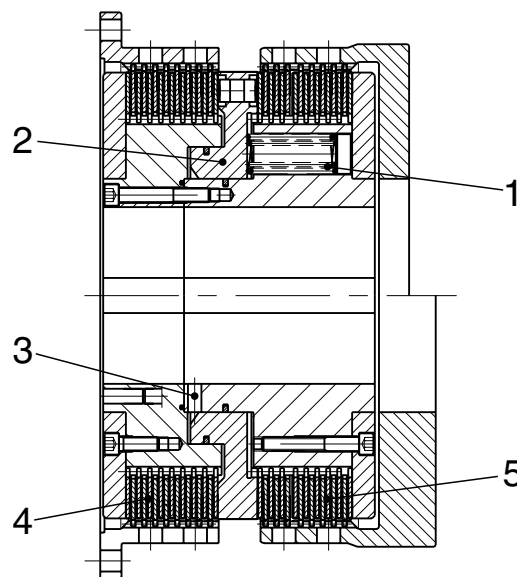

**Fig. 1 Function of the clutch/brake combined unit**

**Braking:** Springs 1 load piston 2 in the cylinder. As a result there is a frictional connection between the brake plates and the brake is activated in this way.

**Engaging of the clutch:** Hydraulic oil 3 moves the piston against the force of the springs. As a result the brake plates 4 are forced apart and there is a frictional connection between the clutch plates 5.

The operating pressure is:

| Size                     | 94               | 96               | 98               |
|--------------------------|------------------|------------------|------------------|
| Operating pressure [bar] | 87 <sup>+5</sup> | 86 <sup>+5</sup> | 84 <sup>+5</sup> |

**Never** operate the clutch/brake combined unit **with a higher pressure** since otherwise there is the risk of screws shearing.

Fit a throttle directly upstream of the main valve in order to prevent short-term pressure peaks in excess of **95 bar**.



**Delivered state**

The clutch/brake combined unit is supplied with the housings in place. In addition the brake plates are already centered and aligned.



**Transport**

Avoid hard impacts during transport which might change the alignment and centering of the brake plates.

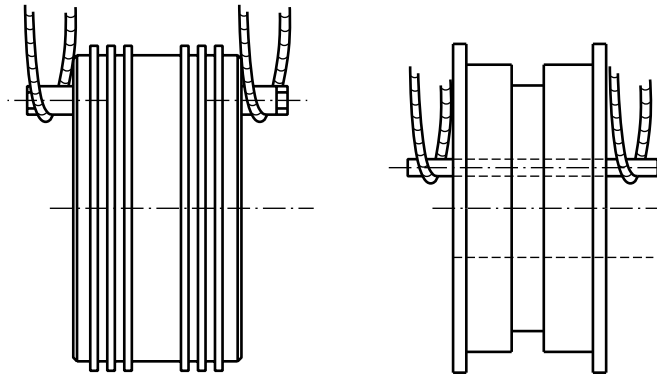

**Fig. 2 Transport aids**

You can fit transport aids as shown. To accept screws or eyebolts there are three free tapped transport holes in each stop disc.

**Size of the tapped transport holes**

|        |     |     |     |
|--------|-----|-----|-----|
| Size   | 94  | 96  | 98  |
| Thread | M20 | M24 | M30 |

**Different versions**

Clutch brake combinations in Range 0123 are available, both on the clutch side and on the brake side, in two design variants which can be combined with each other:

- Standard version (14 friction surfaces)
- Strengthened version with lengthened set of plates (20 friction surfaces)

## Initial assembly and commissioning

The clutch/brake combined unit is supplied with the clutch and brake housing fitted. The brake plates have been aligned and centered in our works.

We cannot here go into special ways of fitting the unit to particular designs of machine. One can however differentiate between two different basic ways in which the unit can be fitted:

### Basic fitting variants

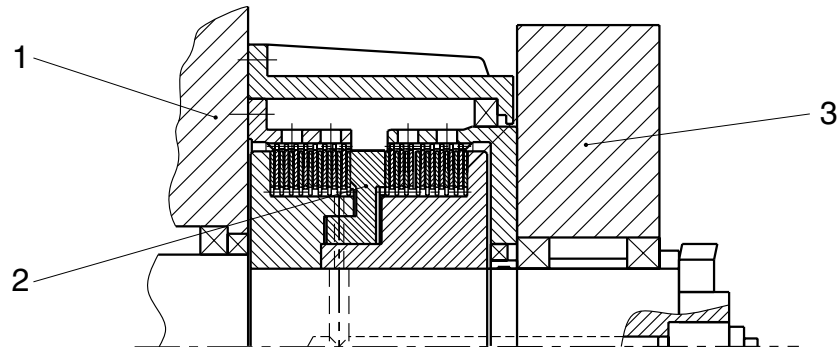

**Fig. 3 Fitting variant 1**

- Clutch/brake combined unit **2** fitted between machine body **1** and flywheel **3**.

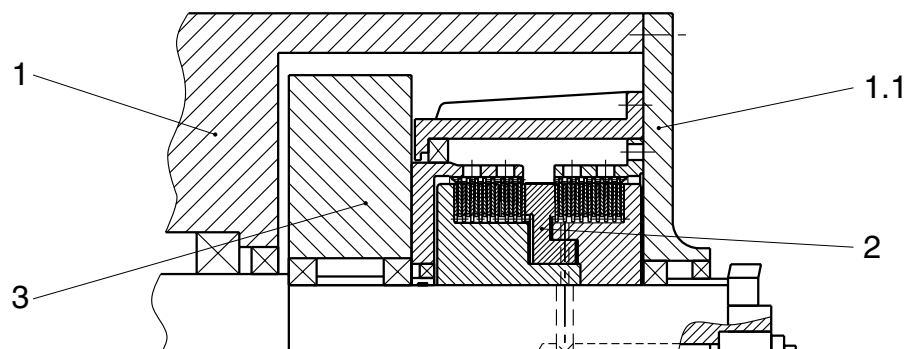

**Fig. 4 Fitting variant 2**

- Clutch/brake combined unit **2** fitted between flywheel **3** and machine body plate **1.1**.

### Fitting the clutch/brake combined unit between machine body and flywheel (fitting variant 1)

- Remove clutch and brake housings.
- Secure the brake housing to the machine body.
- Mount the clutch/brake combined unit on the shaft with feather keys (apply copper-base friction-reducing paste thinly - do not use paste containing graphite).
- Fit housing cup (accessory) to the machine body.
- Mount clutch housing to the flywheel.
- Slide the clutch housing with flywheel on to the clutch/brake combined unit, guiding the clutch plates into the tothing in the housing.

## Fitting the clutch/brake combined unit between flywheel and machine body plate (fitting variant 2)

- Remove clutch and brake housings.
- Mount clutch housing to the flywheel.
- Mount the clutch/brake combined unit on the shaft with feather keys (apply copper-base friction-reducing paste thinly - **do not use paste containing graphite**), guiding the clutch plates into the tothing in the housing.
- Secure the brake housing to the machine body plate.
- Fit housing cup (accessory) to the machine body plate.
- Slide the machine body plate with brake housing and housing cup on to the clutch/brake combined unit.
- Connect the machine body plate to the machine body.

## Test run of the clutch/brake combined unit

The clutch/brake combined unit must be test-run for at least 20 hours. As a rule no further plate wear will take place after this.

## Maintenance

### Checks during the operation of the machine

The clutch/brake combined unit is wear-free and maintenance-free to a large extent.

However wear can take place if the unit is used improperly (too low oil pressure, too high operating temperature ....)

Plate wear manifests itself in the form of the operating characteristics of the clutch/brake combined unit changing, i.e.:

- the braking angle increases, i.e. the press ram travels beyond the top dead point before it comes to a halt, and
- the clutch slips.

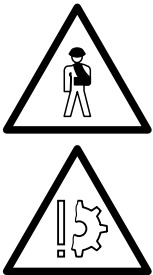

If you find that the braking angle has increased or that the clutch is slipping, stop using the machine immediately and get customer service assistance.

## Fault finding

| Fault                                 | Reason   | Remedy  |
|---------------------------------------|--|---|
| Clutch slips                          | Oil pressure too low   | Increase the operating pressure to the value in the Table on Page 3 below |
|                                       | Fault in the hydraulic system (dirt,, leaks ...)                             | Repair hydraulic system   |
|                                       | Friction linings worn down (maximum permissible size of the air gap reached) | Get customer service to change the plates                                 |
|                                       | Reason cannot be established<br><b>machine-damage</b>                        | Obtain technical service  |
| Brake slips (braking angle increased) | Friction linings worn down (maximum permissible size of air gap reached)     | Get customer service to change the plates                                 |
|                                       | Reason cannot be established<br><b>machine-damage</b>                        | Obtain customer service   |



If plate wear has taken place, then the clutch/brake combined unit must have been improperly operated (too low operating pressure, too high operating temperature ...). For this reason you should establish the way in which the unit has been improperly operated and correct this so that further wear does not occur in the future.

## Complete assembly - only for customer service

**Preliminary remarks:** When ordering a new set of plates, always order at least three filler plates at the same time.

### Checking for wear prior to dismantling

Check the plates for wear before dismantling the unit. For this make the clutch housing accessible.

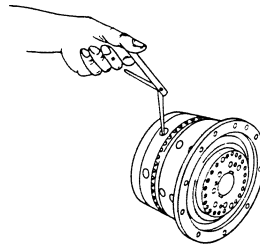

**Fig. 5 Air gap**

- The measurement of the air gap is done through the openings in the clutch housing, between an inner disc and the lining of an outer disc.

### Air gap between inner plate and friction lining of the outer plate

In continuous operation the air gaps will increase as a result of the normal running-in process of the frictional faces. The air gaps in the run-in state of the plates can be calculated as follows:

$$L_{\text{ein}} = L_{\text{neu}} + (AL_{\text{ges}} \times 0,1)$$

- $L_{\text{neu}}$  - Air Gap, new state
- $L_{\text{ein}}$  - Air gap, run-in state
- $AL_{\text{ges}}$  - Number of external plates of clutch and brake

| Size | Air gap $L_{\text{neu}}$ (New state) [mm]<br>make up of plate pack <sup>1</sup> |                               |
|------|---|-------------------------------|
|      | Standard version<br>7 AL  | Strengthened version<br>10 AL |
| 94   | 1,8 - 2,2   | 3,1 - 3,5                     |
| 96   | 2,1 - 2,5   | 3,3 - 4,0                     |
| 98   | 2,4 - 2,8   | 3,7 - 4,4                     |

- AL - outer plates

<sup>1</sup> make up of the larger plate pack (= greater number of outer plates) in clutch or brake.



If the air gap  $L_{\text{ein}}$  is exceeded we recommend that you carry out an inspection. If the air gap reaches twice the size of the new state ( $2 \times L_{\text{neu}}$ ), an inspection must be carried out without fail.

### Dismantling

Before starting work on the machine, make certain that no unintended machine movement can take place as a result of the brake being deactivated.



- Traverse the press ram to its lower dead point.
- - **Switch off the drive**

Slacken the brake and clutch housings and draw the clutch/brake combined unit off from the shaft. For the drawing off operation, you can use the tapped transport holes of which there are. There are three tapped transport holes in each of the stop discs.



Always dismantle the clutch side first and then the brake side.

### Dismantling the clutch side

The stop plate is under spring pressure. It could release itself suddenly and spring out if you just took the screws out.



- For this reason first replace three of the screws with longer auxiliary ones (see table on p. 13).

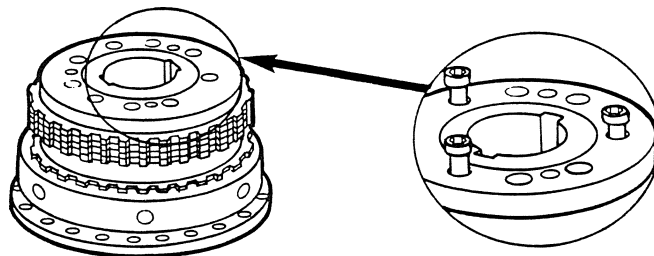

**Fig. 6 Safeguarding at dismantling**

- Then slacken and remove the remaining ones and finally the auxiliary ones.
- Remove the plate set.



### Dismantling the brake side

Always dismantle the clutch side first and then the brake side.

- Unscrew screws and remove the stop plate.
- Remove the plate set.
- Unscrew screws and separate cylinder, piston and hub.

### Assembly of the dismantled clutch/brake combined unit

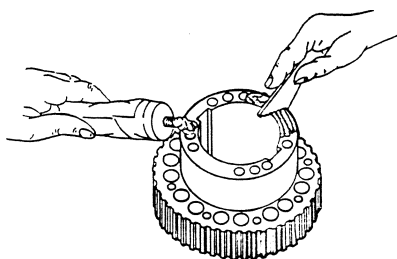

#### Fig. 7 Sealing

The clutch/brake combined unit is assembled in the reverse order to that for dismantling. Observe hereby the following points:

- Degrease all individual parts.
- Seal the face of the hub that contacts the cylinder with Permantex Form-a-Gasket No. 2 (as sold by Loctite).
- Apply the sealant thinly with a serated stopping knife and wait until the surface become sticky.
- Fit O-ring **22** into the groove in cylinder **2**.

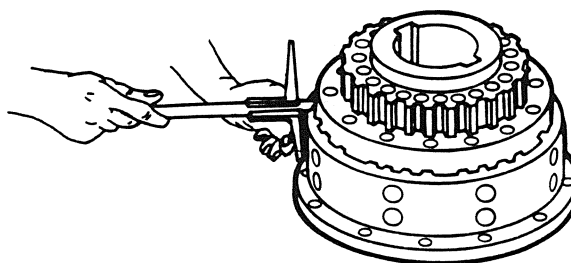

#### Fig. 8 Centring the plate sets

- Align and centre the sets of plates.

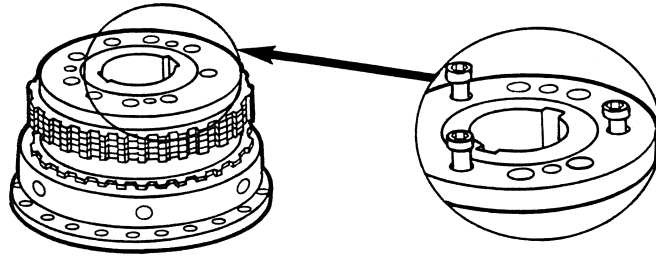

**Fig. 9 Auxiliary screws**

- When mounting the stop plate on the clutch side, first insert and tighten up the longer auxiliary screws and then the original ones. Finally replace the auxiliary ones

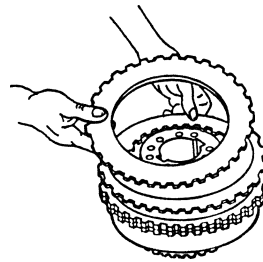

**Fig. 10 Inserting the plates**

- When inserting the plates, observe the following sequence: Inside plate, outside plate, ..., inside plate

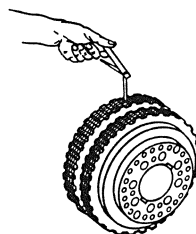

**Fig. 11 Air gap**

- Measure air gap.

### Air gap between inner plate and friction lining of the outer plate

In continuous operation the air gaps will increase as a result of the normal running-in process of the frictional faces. The air gaps in the run-in state of the plates can be calculated as follows:

$$L_{\text{ein}} = L_{\text{neu}} + (AL_{\text{ges}} \times 0,1)$$

- $L_{\text{neu}}$  - Air Gap, new state
- $L_{\text{ein}}$  - Air gap, run-in state
- $AL_{\text{ges}}$  - Number of external plates of clutch and brake

| Size | Air gap $L_{\text{neu}}$ (New state) [mm]<br>make up of plate pack <sup>1</sup> |                               |
|------|---|-------------------------------|
|      | Standard version<br>7 AL  | Strengthened version<br>10 AL |
| 94   | 1,8 - 2,2   | 3,1 - 3,5                     |
| 96   | 2,1 - 2,5   | 3,3 - 4,0                     |
| 98   | 2,4 - 2,8   | 3,7 - 4,4                     |

AL - outer plates

<sup>1</sup> make up of the larger plate pack (= greater number of outer plates) in clutch or brake.

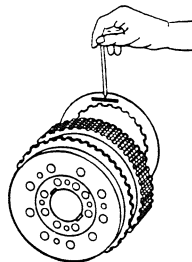

**Abb. 12 Filler plates**

- To set the air gap, use filler plates in place of inside plates.

### Size and tightening torques of the screws

(see sectional drawing at the end for numbering)

Strength class: 10.9

Locking: LOCTITE Type 262

| Size | Item 20 | Auxiliary screw for 20 | 21      | 4 for brake side standard version | 4 for brake side reinforced version | $M_A$ [Nm] |
|------|---------|------------------------|---------|-----------------------------------|-------------------------------------|------------|
| 94   | M20x80  | M20x100                | M20x80  | M20x110                           | M20x160                             | 620        |
| 96   | M24x100 | M24x110                | M24x100 | M24x140                           | M24x200                             | 1060       |
| 98   | M30x110 | M30x130                | M30x110 | M30x160                           | M30x220                             | 2100       |

## Spare parts

Our guarantee for our products only applies when you use original Ortlinghaus spare parts. Please order spare parts only in writing.

You will find the fabrication number, under which your clutch/brake combined unit was manufactured, on the outside of the piston.

Always state this number. It is made up of two digits for the year and a consecutive number, e.g. 00/12345.

In addition please state if possible the article number of your clutch/brake combined unit.

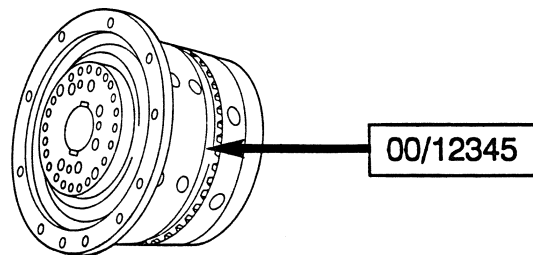

**Fig. 13 Fabrication number**

## List of parts

(see sectional drawings)

| Item | Part                                |
|------|-------------------------------------|
| 1    | Hub                                 |
| 2    | Cylinder                            |
| 4    | Screw                               |
| 5    | Brake housing (here flange housing) |
| 6    | Clutch housing (here pot housing)   |
| 7    | Piston                              |
| 9    | Stop plate                          |
| 11   | Spring                              |
| 12   | Spring                              |
| 15   | Outer plate                         |
| 16   | Inner plate                         |
| 17   | Oblong ring                         |
| 18   | Oblong ring                         |
| 19   | Damping element                     |
| 20   | Screw                               |
| 21   | Screw                               |
| 22   | O-ring                              |

**Parts -single brake**

**Brake**

**Clutch**

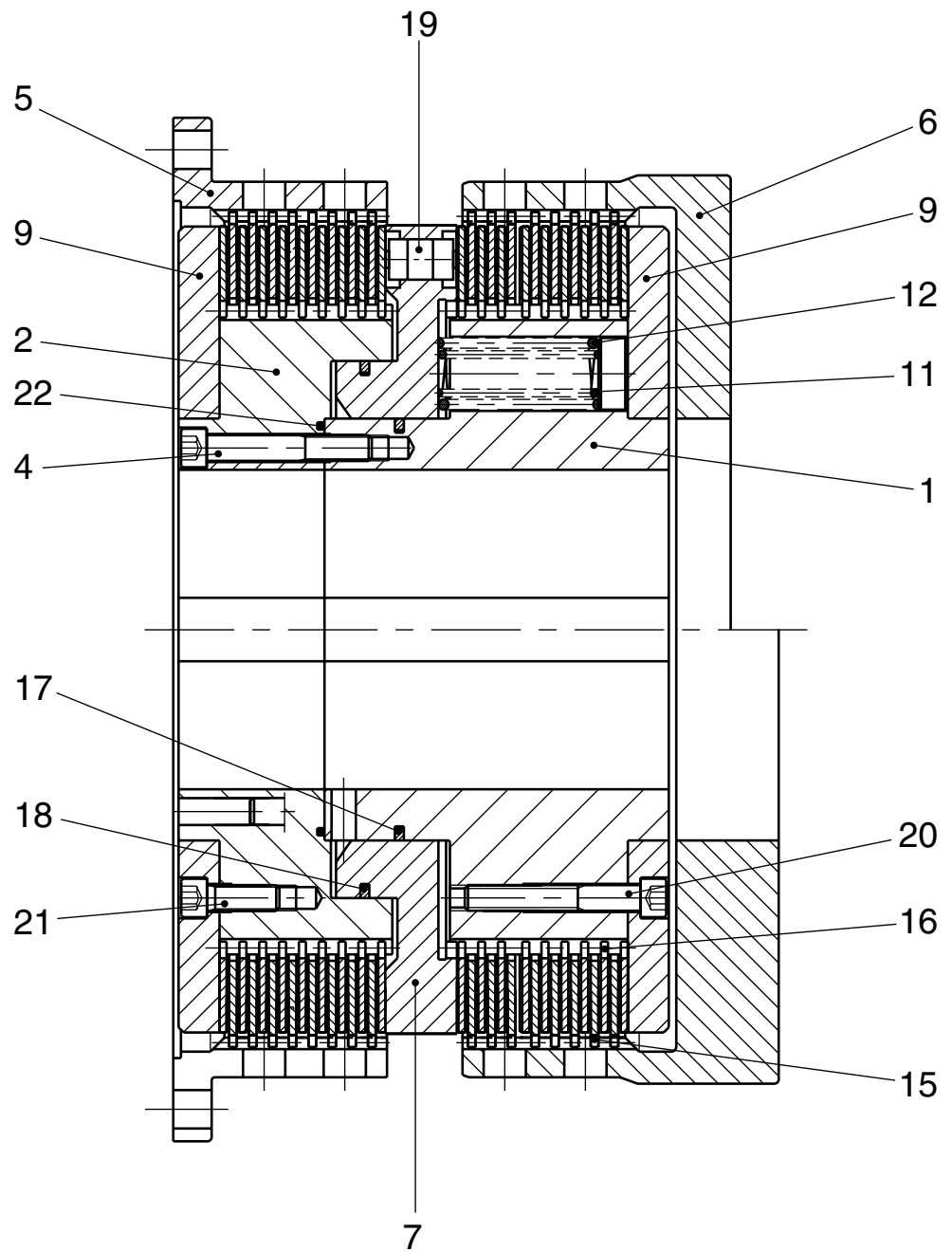

(20) Same dimension for standard and reinforced versions

## Approved types of oil

We have cleared the following types of oil for operation of the clutch. They have been tested by us and give an optimal performance.

| Oil type                 | Manufacturer       | Trade name              |
|--------------------------|--------------------|-------------------------|
| HL/CL                    | Agip               | Agip OTE 32...68        |
|                          | ARAL               | Kosmol TF 32...68       |
|                          |                    | Vitam UF 46, 68         |
|                          | BP                 | BP Energol HL 46        |
|                          | DEA                | Astron HI 22...68       |
|                          | FINA               | CIRKAN 22...68          |
|                          | MOBIL              | Mobil Turbine Oil Light |
| Mobil Turbine Oil Medium |                    |                         |
| SHELL                    | Morlina 22, 46, 68 |                         |
| ATF                      | Aral               | ATF 33                  |
|                          | BP                 | Autran G                |
|                          | Esso               | Glide                   |
|                          | FUCHS              | ATF TF M2C 33-F         |
|                          | MOBIL              | ATF 210                 |
|                          | SHELL              | ATF Donax TF            |
| Synthetic oils           | CASTROL            | Alphasyn T 32-68        |
|                          | MONSANTO           | Santotrac 20-50         |