

Pneumatically-actuated single and two plate clutches with linings

Series 0-442-..7-
Size 66 -93
Issue 03.1989

1. Function

The housing (21) is centred on the flywheel or gear wheel or, when used as a brake on the machine frame. It is secured with studs (23), which should be secured with Loctite, and hexagon nuts (24) with conical lockwashers (25) and should if possible be pinned. The housing is internally splined to accept pressure plate (15) and outer plates (18). The linings (20), which are guided in housing plates (19.2), lie between the outer plates (18) and between one outer plate and the pressure plate (15). The housing plates are centred on the hub (19.1) with a ring (19.3) and are connected to the hub with screws (19.4) and taper pins (19.5). The piston (2) can be displaced axially in cylinder (1) and is sealed to prevent air escaping with U-seals (3/4). When compressed air is fed into the cylinder through the flange (5) and the unions (7/8/9) and pipe sections (10), the piston (2) with the pressure plate (15) is displaced axially and presses the linings (20) and the outer plates (18) together to give a non-positive connection and the transmission of the coupling torque. When the air pressure is released, the springs (11/12) return the pressure plate (15) and the piston (2) to their rest position.

Operating pressure 5.5 bar.

Max. permitted operating pressure 6 bar.

2. Installation

2.1 When a new clutch is supplied

The clutch as supplied must be installed as follows. Screw studs (23) into the flywheel or gear wheel and secure with Loctite. Place housing (21) onto centering studs. Slide the first outer plate (18) into the housing. With the two plate version, slide the hub (19.1) with housing plate (19.2), ring (19.3), linings (20), second outer plate (18) as well as screws (19.4) and taper pins (19.5) on to the shaft and secure. With the single plate version, slide hub (19.1) with housing plate (19.2), linings (20) as well as screws (19.4) and taper pins (19.5) on to the shaft and secure. Slide the actuator, which is a sub-assembly consisting of the piston (2) with U-seals (3/4), cylinder (1) with flange (5) and unions (6/7/8/9) with pipe sections (10) as well as pressure plate (15) with studs (15.1), bush (14), washers (13) and hexagon nuts (16) with lockwashers (17), on to the studs (23).

In the case of the two plate version, slide in spacers (22) between housing (21) and cylinder (1) and secure with hexagon nuts (24) and lockwashers (25). No spacers are needed with the single plate version. Tighten up hexagon nuts (24) to the torque specified in table 3. It must be possible to turn the housing easily when idling.

It is essential that the linings are kept free of grease and oil!

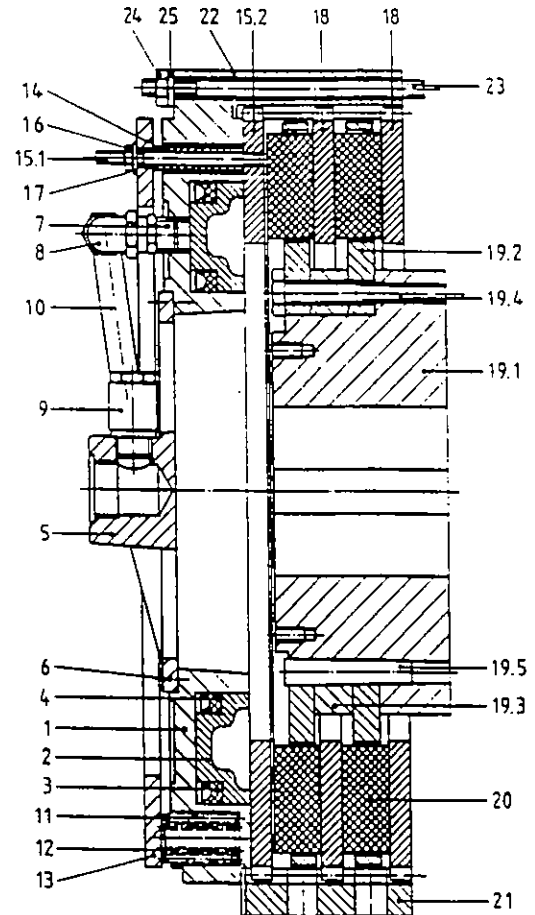

Fig. 1 Two plate version

2.2 After replacing the linings

In the case of the single plate version, insert linings (20) into the housing plate (19.2). Slide the actuator on to studs (23) and bolt to the housing (21) with hexagon nuts (24) and lockwashers (25). Tighten up hexagon nuts (24) to the torque specified in table 3.

In the case of the two plate version, insert linings (20) into the first housing plate (19.2). Slide the second outer plate (18) into the housing (21). Slide ring (19.3) with the second housing plate (19.2) on to the hub (19.1), align and screw up loosely with screws (19.4). Take care here that the three holes for taper pins (19.5) are properly aligned in all component parts. Insert taper pins (19.5). Tighten up screws (19.4) to the torque specified in table 3 and hammer in taper pins (19.5) firmly. Slide the actuator on to studs (23), insert spacers (22) and bolt to the housing (21) with hexagon nuts (24) and lockwashers (25). Tighten up hexagon nuts (24) in accordance with table 3.

3. Adjustment for wear

In the case of the single plate version, the point of max. permissible wear has been reached when the washer (13), which is connected in a fixed manner to pressure plate (15), can make contact with the cylinder (1). The linings (20) must now be renewed. In the case of the two plate version, only half the permissible wear has taken place at this point. This wear can be compensated for by removing spacers (22). To do this, slacken hexagon nuts (24), remove spacers (22) and then tighten up hexagon nuts (24) again to the torque specified in table 3. The point of max. permissible wear has been reached when the washer (13) can again make contact with the cylinder (1). The linings (20) must now be renewed.

4. Renewing the linings

Slacken and remove hexagon nuts (24) with lockwashers (25). Remove the actuator. Replace linings (20). In the case of the two plate version, remove the first layer of linings (20) as above. Then remove taper pins (19.5). Slacken and remove screws (19.4). Remove the first housing plate (19.2), ring (19.3) and outer plate (18). Replace the second layer of linings (20). Reassemble as described under 2.2.

5. Spare parts

When ordering spare parts, please always quote the serial number of the clutch, which is marked on the housing or hub, as well as the number and designation of the spare part required. To avoid the possibility of errors, all orders should be placed in writing.

6. Linking of a clutch with a pneumatically-released brake.

The times during which the brake is applied must not overlap (coincide) with the times during which the clutch is engaged since otherwise the plates will wear and heat up too much. When air is released from the cylinder, the brake is automatically applied as the result of the spring pressure acting on it. When compressed air is applied, the brake is released. The following circuits are possible:

6.1 Using one valve

(Spring return pressure acting on clutch and brake the same). Actuation of the solenoid valve causes both the clutch and brake cylinders to be pressurised. The clutch springs must be dimensioned in such a way that the clutch must not engage until the brake has been released. Thus the spring return pressure acting on the brake must be equal to or can be up to 0.2 bar less than that acting on the clutch. Overlapping of the engagement of the brake and the clutch cannot take place with this arrangement.

6.2 Using two valves

(Spring return pressure acting on clutch and brake not the same). If the spring return pressure of the brake is greater than that of the clutch, overlapping can be avoided by using pressure-sequence-controlled valves. In the valve circuit shown in fig. 2, clutch and brake are controlled electrically by separate 3-way valves. Pressure switches are provided in the control lines between the clutch/brake and their respective valves. These bring about the engaging/disengaging of one working element when the pressure acting on the other working element has reached a particular preset level.

7. Faults and their elimination

Clutch starts to slip:

Cause: The wear on the linings is too large. Renew the linings.

Cause: The air pressure is lower than that required. Unless otherwise stated, the clutch requires an air pressure of 5.5 bar.

Clutch overheats:

If the heating up takes place at the housing bearing, care must be taken that the bronze bushes, roller bearings or similar are adequately greased.

At high engagement frequencies or where high masses have to be braked, heating up of the clutch cannot be avoided since the work of friction is inevitably released as heat. If temperatures of over 80 °C on the cylinder or 100 °C on the housing are found, steps must be taken to improve the removal of the heat. If the above-mentioned temperatures are exceeded for any length of time, the U-seals will vulcanise and become hard and brittle. They will then no longer be airtight and must be renewed.

Cause: The functioning of the clutch and brake are overlapping. This must be prevented as described in para. 6.

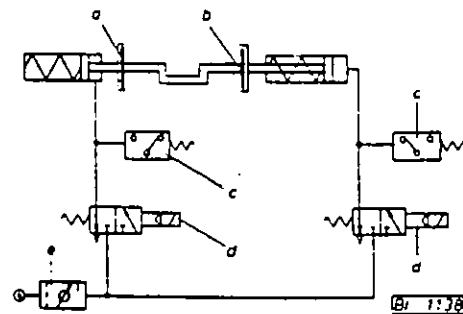

Fig. 2

- a Brake
- b Clutch
- c Pressure switch
- d 3/2 way valve
- e Oiler

8. Ancilliary equipment

8.1 Compressed air supply

When there is no compressed air supply line, the size of the compressor required must be determined in accordance with the air consumption of the clutch. See table 1 for the cylinder volumes. To the cylinder volume must be added the volume of the lines from the compressor up to the valve. The quantity of air required is then:

$$Q = 1.5 \cdot V \cdot p \cdot z = \text{quantity of air drawn in by the compressor (l/min.)}$$

V = cylinder volume + volume of line between clutch and valve in litres.

p = max. operating pressure in bar.

z = max. number of engagements per minute.

1.5 = factor for leakage losses.

Where a compressor supplies more than one clutch, the quantity of air required will be correspondingly greater.

Attention: Use only filtered air!

8.2 Air inlets

Air inlets can be supplied. Care must be taken that these are fitted in a true and airtight manner to the flange since otherwise their proper functioning and long service life cannot be guaranteed. They should be connected to the air pipe by a flexible metal hose with a length of at least 300 mm in order to ensure that the air inlet is not stressed. Max. operating pressure 6 bar. Maintenance: Top up with 6-8 g roller bearing grease after some 7,000 operating hours.

8.3 Accumulator

Where high engagement frequencies arise, it is advisable to fit an appropriately sized accumulator immediately before the valve in order to ensure that there is always sufficient pressurised air available to actuate the unit.

Volume of the accumulator:

$$V_{acc.} = 15 \text{ to } 20 \cdot (V_{cyl.} + V_L)$$

V_{cyl.} = max. cylinder volume (table 1)

V_L = volume of line between valve and clutch

It is of advantage to fit a pressure monitor in order to be able to monitor the operating pressure since, if the air pressure is too low, the clutch can slip and then fail as the result of

overheating or wear. The air pressure measured directly before the clutch should not fall below 90 % of the operating pressure when the clutch is being engaged.

Operating pressure required 5.5 bar
Max. permissible operating pressure 6 bar.

Size	Cylinder volume in l when new	with max. wear
66	0.20	0.34
72	0.27	0.51
75	0.30	0.60
78	0.39	0.77
80	0.42	0.97
84	0.56	1.27
85	0.87	2.23
90	1.14	2.44
91	1.87	3.68
93	3.66	6.85

Table 1

Size	Nominal size of the valves and air inlets
66	G 3/4 A
72	G 1 A
75	G 1 1/2 A
78	G 1 1/2 A
80	G 1 1/2 A
84	G 1 1/2 A
85	G 2 A
90	G 2 A
91	G 2 A
93	G 2 A

Table 2

8.4 Lines and pipes

For rapid switching when manufacturing with presses, the diameters of the pipes and lines must be in accordance with table 2 since otherwise exact switching will not be achieved.

The oiler (3 in fig. 3) must be set in such a way that 1 to max. 3 drops of oil are added to the air for each cu. metre air.

Schematic of a compressed air unit

- 1 Compressed air filter
- 2 Pressure regulating valve
- 3 Oiler
- 4 Accumulator
- 5 Flexible metal hose
- 6 Solenoid 3-way or press safety valve
- 7 Air inlet
- 8 Clutch
- 9 Non-return valve

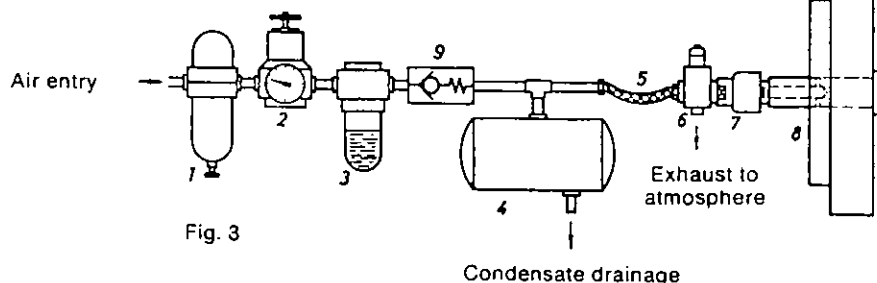

Fig. 3

Table 3 Individual parts acc. to fig. 1	Size of the clutch											Strength class	Secured by
	66	72	75	78	80	84	85	90	91	93			
1 Cylinder													
2 Piston													
3 U-seal													
4 U-seal													
5 Flange													
6 Screw Nm	8.5	14	14	14	14	14	35	35	35	69	10.9	Torque	
7 Screw-in union													
8 Angle union													
9 Swivel union													
10 Pipe section													
11 Spring													
12 Spring													
13 Washer													
14 Bush													
15 Pressure plate													
15.1 Stud													
15.2 Outer plate													
16 Hexagon nut Nm	25	49	25	86	49	86	86	210	210	410	10	Torque	
17 Lockwasher													
18 Outer plate													
19 Hub													
19.1 Hub													
19.2 Housing plate													
19.3 Ring	not required with single plate version												
19.4 Screw Nm	69	120	120	120	295	580	580	1000	1000	1000	10.9	Torque	
19.5 Taper pin													
20 Lining													
21 Housing													
22 Spacer	not required with single plate version												
23 Stud													
24 Hexagon nut Nm	69	69	120	120	190	295	295	580	580	1000	10	Torque	
25 Lockwasher													
Total wear of the linings	single plate mm	4.35	5.35	5.5	5.3	6.5	7	7.5	8	8.5	9		
	two plate mm	7.6	9.7	9.8	9.8	12	13	14	15	16	18		

Ortlinghaus-Werke GmbH

5632 Wermelskirchen 1

Postbox 14 40
 Telephone (02196) 85-0
 Telefax (02196) 93625
 Telex 8 513 311