

1. Description

The highly flexible coupling is a pliable, shock absorbing and angular motionable shaft clutch. The unit consists of a quadrangular, sexangular, respectively octangular designed GOETZE-Giubo Coupling (Patent Saga) as well as of two coupling halves. To connect the flexible ring with the coupling halves and to transmit the torque, two screws type 8 G are required (dowel pins are not required). The highly flexible ring consists of cylindrical rubber bodies with clamping sleeves of steel plate vulcanised on to the edge points. The bores in the clamping sleeves serve to accept the fixing screws.

2. Incorporation of the couplings

Please watch the following points when incorporating the couplings:

The shaft bearings should be placed as near as possible to the coupling.

Accurate alignment of the shafts is recommended, particularly when working at high revolution figures.

The incorporation of the highly flexible ring is done in a radially pre-tensioned condition. The required pressure tension is reached through a metal band which is placed around, and reduces the diameter of the ring to the nominal diameter and which in this way allows the mounting of the coupling halves. The tension band can only be removed after assembly, the tension is now maintained through the fixing screws. If the ring is temporarily disassembled, the tension band, respectively the hose clamp, must be placed around the coupling ring in order to maintain the tension as otherwise assembly is not any more possible.

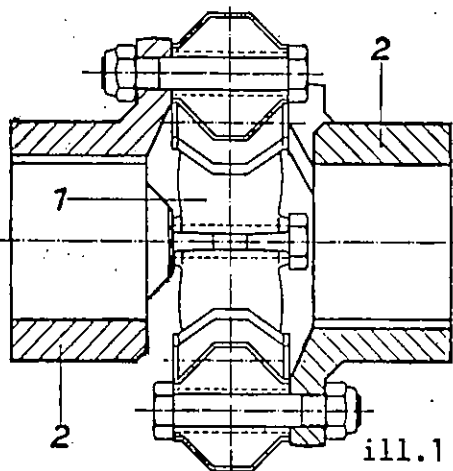

2.1 Double Hub Design 0-007-033-...-000 (illustration 1).

Both coupling hubs (2) are to be firmly connected on the shaft ends and should be protected against axial displacement. The highly flexible ring (1) is fixed on a coupling hub through screws. The shaft which is to be connected, is to be drawn nearer and the highly flexible ring is screwed to the second coupling half. It should be watched that the self adjusting nuts are placed on the flange of the coupling hub. Examine the nuts regarding firm fit and remove the metal band.

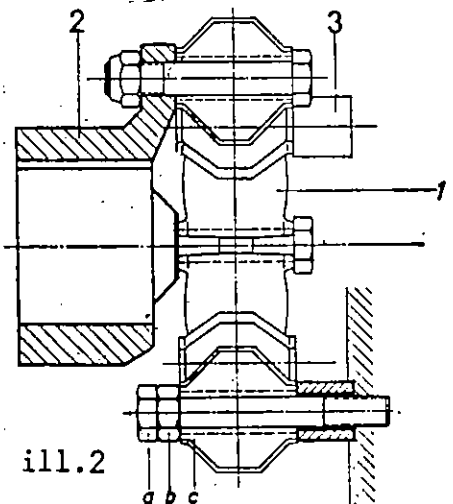

2.2 Combined Hub Flange Design. (illustration 2)  
0-007-039-001 (standard design)  
0-007-039-000 (short design)

Connect the coupling hub (2) firmly on the shaft end and secure against axial displacement. The highly flexible ring (1) is fixed to the coupling hub with screws. It has to be watched that the self adjusting nuts are placed on the flange of the coupling hub.

After putting the nuts (b), the coupling ring (1) and the distance bushes (standard and short design) (3) on the screws (1) the shaft is to be moved nearer and the connecting part is to be screwed to the highly flexible ring. When tightening the

screws (a) the nuts (b) are to be secured through a spanner to prevent turning of the clamping sleeves. Check screw connections for solid seat and remove metal band.

Das Urheberrecht an dieser Zeichnung gehört uns. Laut Urheberrechtsgesetz, Wettbewerbsgesetz und BGB ist Vervielfältigung oder Mitteilung an dritte Personen unzulässig und strafbar. Änderung vorbehalten.

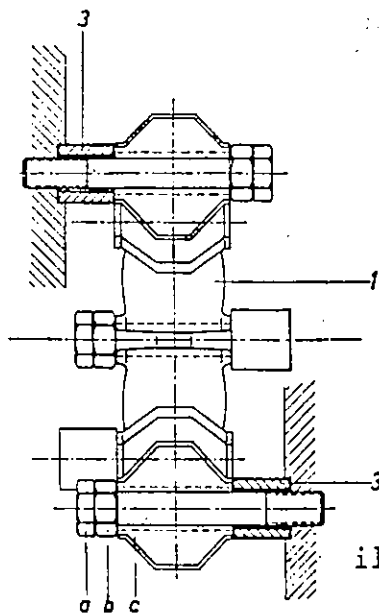

ill.3

### 2.3 Double Flange Construction 0-007-032-...-002 (illustration 3)

After placing the nuts (b), the coupling ring (1) and the distance bushes (3) on the screws (a) the ring is to be screwed on one side. The second connecting part is to be moved forward and is also to be screwed to the ring. When tightening the screws (a) the nuts (b) should be held through a spanner to prevent turning of the clamping sleeves (c). Check screw connections regarding firm fit and remove the metal band.

It is recommended to centre the distance bushes in the counter piece.

### 3. Required Screw Traction Torques.

Correctly braced connection is only achieved if the traction torques given in the table are observed when assembling. Tightening by means of a torque spanner is recommended.

ORTLINGHAUS-clutch-size	with screw-Ø	required tightening torque (kpm)
11	M 8	2,5
15	M 8	3,5
23	M 10	4,7
31	M 12	7,8
39	M 14	12
47	M 20	33
55	M 20	33
63	M 20	33
69	M 27	80

### 4. Spare Parts

When ordering spare parts please state the factory number on the coupling halves or send a sample of the required spare. To avoid errors please place your spare orders either in writing or by telegram.

### 5. Heat Resistance

The coupling rings are normally made of natural coutchouc, which is heat resisting up to approx. + 70°C and can be used in a low temperature of up to - 25°C. Fractures through freezing in of the mixture are not to be expected at this temperature.

### 6. Resistance to Oil

The coupling rings made of natural coutchouc are not oil resisting. This, however, at the relatively large diameters does not mean that the coupling rings must not get into temporary contact with mineral oils, grease etc. Larger quantities of oil and grease are in any case thrown off when coupling operates. It should however be understood that the coupling rings cannot run in an oil bath.

**ORTLINGHAUS-WERKE GMBH** · 5678 **WERMELSKIRCHEN-RHLD.**  
WESTERN-GERMANY

Tel.: Wermelskirchen 851 · Telex: 8 513 311 · Telegrams: Ortlinghauswerk Wermelskirchen